



■ Review of Cgate business

■ Product profile: Snap Frames

■ Tailor made products

■ Customer column

This year Cgate celebrates 3 years in business. The company was established in 2002 by industry and Asia Pacific business experts Eran Baram and Shai Felder. Cgate manufactures digital printing, signage and display products in China. With nearly 30 distributors in over 20 countries worldwide and with multi million dollar sales, Shai believes that Cgate's success can be attributed to the setting up of strategic offices in the right place and at the right time.

Initially, Cgate began developing sales channels for Shanghai based Teckwin, a leading brand manufacturer of large format digital presses. The first distribution channels were set up in Europe. Cgate has negotiated special OEM projects including the bespoke design of machines for leading brands as private labels. Negotiations are now underway to expand the business to the United States.

“Our head office in China has a team of local people with specialist skills”, says Eran. “We have focussed on recruiting people who can deal with the manufacturing process and product qualification. Most importantly, we have set up a unique quality control department to inspect each outgoing shipment both during the manufacturing and packing processes.”

CGATE PRODUCT LINES

A wide range of flexible media for both dye pigment and solvent ink printers including front and backlit banner material, One Way Vision, Mesh and a variety of media for indoor applications

Rigid materials for signage and direct printing such as Free Form PVC, Composite Aluminum panels and Cast Acrylic sheets.

Display products: Light Boxes, Snap Frames, Roll Ups and more.

Cgate is pleased to manage bespoke projects on behalf of customers. See feature on page 2.



Cgate head office in Shanghai

Cgate has two European offices, one in London and the other in Brussels. From these locations Cgate has been able to develop successful business with distributors in all European countries and in South Africa.

TAILOR MADE PRODUCTS

Service providers are more aware than most that many of their customers may not be satisfied with the range of standard products. The costs of manufacturing bespoke items in Europe can be extremely high and may result in the loss of otherwise lucrative contracts.

Cgate offers advice on the viability of outsourced manufacturing from experience working with a number of qualified manufacturers and integrators in China with expertise in producing orders to customer specifications. Production in China of custom made products is most suited to large campaigns for high-end brands. Cgate welcomes enquiries.

SP MEDIA - HEINEKEN PROJECT

SP Media (France) specialises in design and production of large scale display projects such as the Heineken banners illustrated here.

By producing the banners in China in collaboration with Cgate, SP Media has benefited from considerably lower production costs and therefore higher margins.

The project involved sourcing of both electrical and mechanical parts and a variety of different materials, all found locally in China and managed by Cgate's local staff in China.

This project was successfully rolled out in Q2/2005 in over 300 supermarkets throughout France. A European roll-out is planned for later this year.

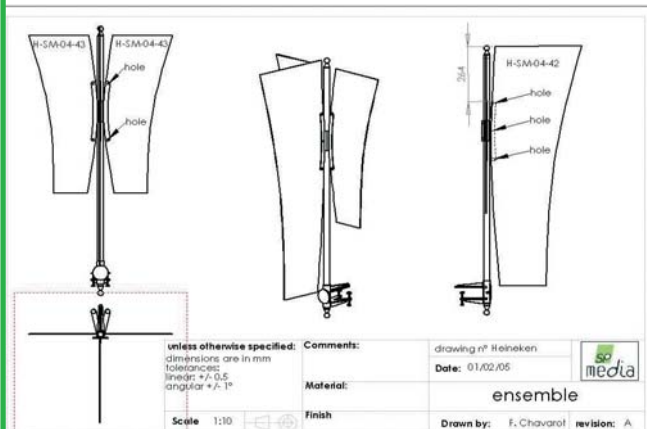

Heineken project display - technical drawings

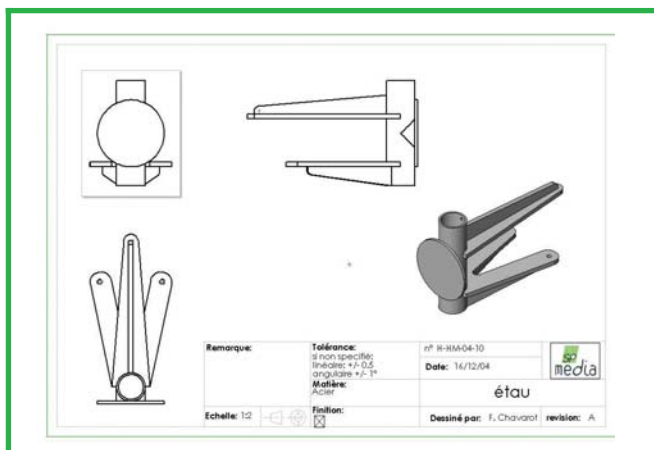

Technical drawings of shelf fixing

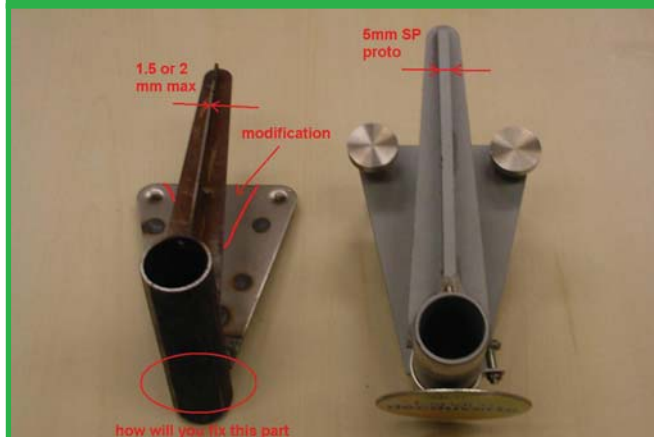

First prototypes of shelf fixings



Banners on display in supermarket



View of product shelves with banners

CUSTOMER COLUMN



Atrium, Poland

Tarra, Iceland

*D.O'Sullivan,
Ireland*

ATRIUM INCREASES MARKET SHARE

Established in 1993, Atrium Centrum Ploterowe supplies the Polish market with large format printing solutions. A distributor for large format printers and cutting machines, they also offer a wide range of consumables including solvent and pigmented inks and flexible media for dye/pigment and solvent printers. Following their success at the "Reklama" show in Poznan, Poland in 2004, Atrium have increased their orders from Cgate and widened the product range.

Atrium's head office is in Opole with branch offices in major Polish cities - Warsaw, Poznan and Gdansk. Within a year they plan to move to new offices with a larger storage facility.



Atrium stand at Reklama trade show

SNAP FRAMES



The best selling line of lightboxes has prompted Cgate distributors to place requests for of snap-frames. After a comprehensive investigation of manufacturing facilities, Cgate is pleased to announce that a wide range of frames can now be ordered. The different colours, finishing options and wide range of profiles will meet the needs of the most demanding customers. In addition to standard sizes, orders can be placed for non-standard sizes.

TARRA

Iceland's complete signage product provider

For over 30 years Tarra Pvt. has been running an import business in Iceland.

Supplying a high quality service to the large format printing and signage industries is a relatively new business for Tarra. The company currently supplies a wide range of consumables including inks, laminate films, a range of flexible and rigid media as well as display items such as roll-ups and advertising stands. Their range of services and products for design companies includes CAD paper, sheet paper, toner, ink and software.

Cgate is the perfect partner for Tarra as they can place a single order for a wide selection of products, sourced from several Chinese manufacturers, to meet customer needs. Cgate takes care of the logistics including packing and shipping, thus saving both time and money.

D. O'SULLIVAN PRINT SUPPLIES

Ireland's largest signage product distributor

The origins of the company go back to 1935. It was registered as a limited liability company on the 18 September 1975 and has remained a private company with the same family ownership for seventy years.

Located in Dublin, the company owns and occupies offices and warehouses covering forty five thousand square feet. D.O'Sullivan is a paper / board merchant and distributor of a variety of rigid media as well as other products for the signage and display industries. They also have distribution rights for several well known brands of digital printing equipment and supply hardware and consumables for the screen printing industry

The partnership with Cgate has enabled D.O'Sullivan to extend their range of signage products and to explore new opportunities offered by the Chinese manufacturers sourced and supervised by Cgate.

Last year the company returned a sales total of approximately €14 million and expects a substantial increase in 2005.

CGATE specialises in bringing high quality Chinese products to the West in the most efficient and cost effective way.

Cgate Head Office

1266, Nan Jing Road West
Plaza 66, 23 Fl, Room 2308
Shanghai 200041
China P.R.C.

Tel: +86-21-6288-2350

Fax: +86-21-6288-2353

Cgate Europe Office (London)

2nd Floor
145-147 St. John Street
London EC1V 4PY

UK

Tel: +44-20 8908 9229

Fax: +44-870 1331153

Email: andi@cgate-enterprise.com

Cgate Europe Office (Brussels)

Rue Heideken 15
1083 Ganshoren
Brussels 1083
Belgium

Tel: +32 2 4286355

Fax: +32 2 4286355

Mobile: +32 486987676

Email: alex@cgate-enterprise.com

Cgate US Office

2915 Pass a Grille Way
St. Pete Beach, FL 33706

Cell: 617 429 6056

Office: 727 367 9793

email: CGATEUSA@aol.com

CGATE DISTRIBUTION CHANNELS

Cgate now has distributors in these countries:

Cyprus

Denmark

Estonia

Finland

France

Germany

Greece

Hungary

Iceland

Ireland

Israel

Italy

Norway

Japan

Poland

Russia

Saudi Arabia

South Africa

Spain

Sweden

Switzerland

Turkey

United Kingdom

United States

Remember:

At Cgate we are always interested to hear from you whether you are interested in our current range of products or in other business opportunities.

For information on any of our products or to become a distributor, please contact us now for details:

Email: info@cgate-enterprise.com