

group

CGATE

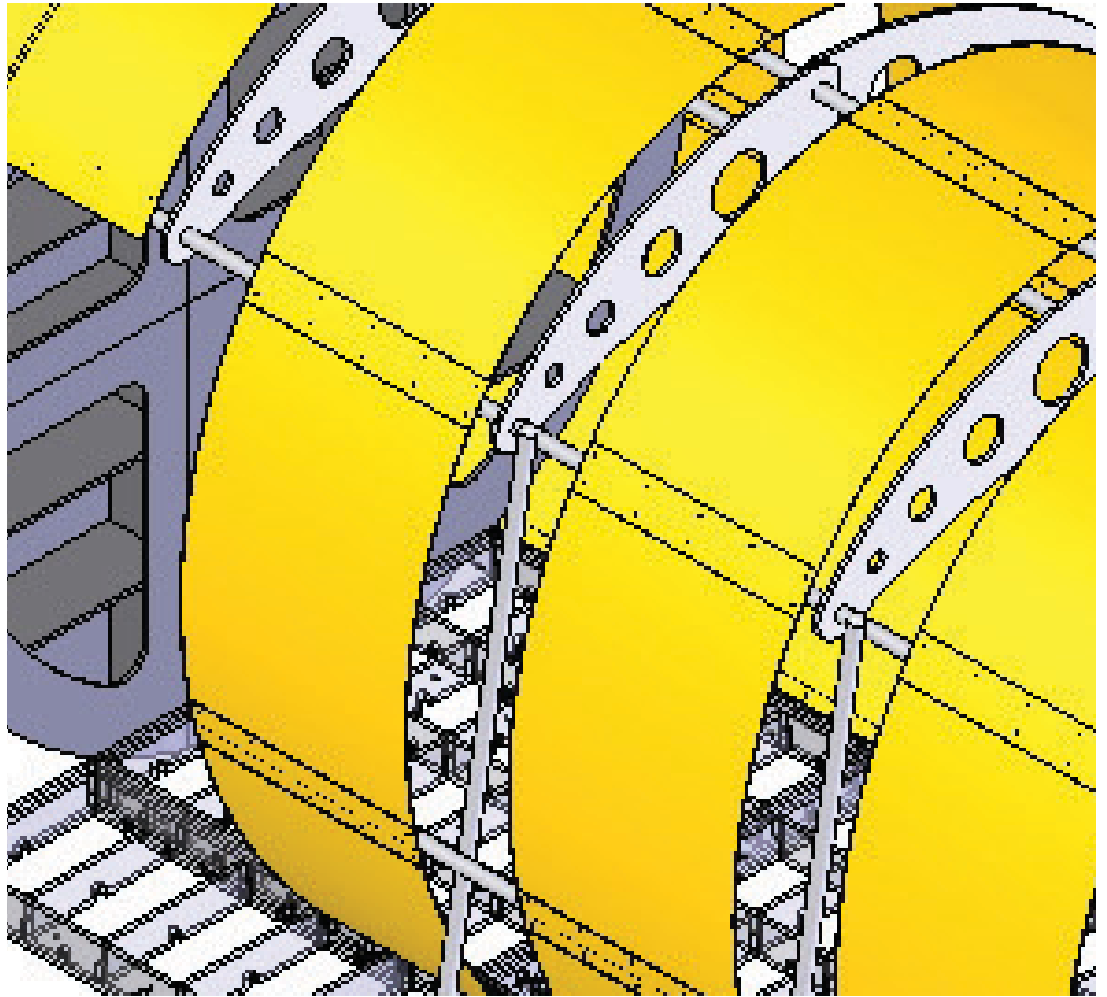

## WANT TO KNOW WHAT'S NEW AT CGATE? VISIT US AT DIGITAL EXPO AND FESPA BERLIN

### In this issue:

A new identity for Cgate  
Cgate 2007 trade show details  
New German office announced  
European storage facility  
IGEPA Group sells Cbond in Europe

### Focus on sign culture

Sign and Display in Iceland  
Reklama show in Poland  
Product profile - PVDF

### A NEW IDENTITY

Doesn't time go quickly when you're having fun!

It has been three exceptionally busy years since Cgate started trading in Europe and we thought it was time to update our logo.

Please look out for our new logo when visiting us at Digital Expo in the UK and at FESPA in Berlin this year.

### DIGITAL EXPO

This year Digital Expo promises to be not only the focus for the sign industry in the UK but will also attract an international attendance.

[www.signuk.com](http://www.signuk.com)

### FESPA BERLIN

The must-go-to show this year for the digital sign and display industries will be, without doubt, Fespa Berlin.

After our success last year in Amsterdam, we simply had to be there.

[www.fespa2007.com](http://www.fespa2007.com)

**DIGITAL EXPO** NEC BIRMINGHAM 1-3 MAY 2007 **STAND F50**  
**FESPA BERLIN** 5-9 JUNE 2007 **HALL 5.2 STAND C832**

## IGEPA GROUP PROMOTES CBOND

The Igepa group is one of Europe's leading paper merchants, with 40,000 clients in 16 different countries. Employing 2,350 people and co-coordinating a network of strategic European partners, the group achieves an annual turnover in the region of 1.55 billion, selling over 1.55 million tons of paper a year.

This year the German based company will start selling Cbond, Cgate's aluminum composite panels, throughout Europe. Cbond will be available initially in the German market through IGEPA subsidiary companies.

The collaboration with IGEPA will help to position Cgate's Cbond as a leading ACP material in the German market which is the largest market for this material in Europe.

[www.igepagroup.com](http://www.igepagroup.com)

## CGATE EUROPEAN STORAGE

In response to customer demand, Cgate now operates a storage facility in Europe. The aim is to be able to respond to more urgent orders and for those customers who cannot justify the purchase of a full container load.

Initially we will stock the most popular sizes of Cbond and other products will be added according to demand.

Please contact us for more details and for a stock list.

## NEW GERMAN OFFICE

Our new office in Germany is now open for business. See details on the back of the newsletter.



## SIGN AND DISPLAY IN ICELAND

Perhaps the reason that one sees so much graffiti around Reykjavik is a result of the rather stringent outdoor advertising rules and regulations.

Indeed, all outdoor advertising has to pass considerable hurdles that include; obtaining the approval of the Building Officer, the Head of Environment of the area in question and the permission of the building owners. Moreover, if the property is owned jointly, all parties are obliged to give their consent.

## A MARKET LEADER

Although Tarra has been in business for over 30 years, their interest in the sign industry is relatively new. Today their market share is about 32%. This makes them a significant player in the sign and display business in Iceland.

Tarra distributes printers from a range of manufacturers including Mimaki, VUTEk, Nur, Scitex and HP as well as laminators from Seal and Mimaki and RIP software from Caldera and Wasatch. This ensures that they can meet the needs of all their customers, large and small.

Managing Director, Kristjan Bergmannsson has a somewhat bemused view of the sign market in Iceland which has led the company to try and stock the widest variety of media including many different items from the Cgate range. In fact, they are in the process of doubling their warehouse space to accommodate even more.





## REKLAMA SHOW IN POLAND

The annual Reklama show in Poznan is a showcase for the rapidly developing sign market in Poland.

This year there was a wide variety of companies, promoting the latest large format printers and a range of media that would not be out of place in any western European country.

Atrium have been a distributor of Cgate products for several years and have seen their business expand steadily in the time that they have been working with Cgate.

“Customers are demanding the best prices for the highest quality products” says Bolek Karmelita, Director for Media at Atrium.

Atrium is proud of the service that they provide which is not only to sell the products demanded by their customers but also to provide quality support and technical advice. ■



## CGATE PRODUCT PROFILE - PDVF ACPs

PVDF ACPs are used chiefly for building cladding and corporate image creation. They meet the high standards required by the construction industry for outdoor durability. PVDF is made to rigorous quality standards and is guaranteed for at least 50 years outdoors.

The panels are made with a combination of PVDF and an externally applied lacquer made from durable

Flouro Carbon which protects the colour from fading over time and in all weather conditions. Sizes are similar to the Cbond range and sheets come in 3 and 4mm thicknesses with skins of 0.3, 0.4 and 0.5mm. All RAL colours can be matched.

Cgate would like to make contact with high-end users requiring construction standard materials meeting ASTM standards.



## CGATE IN BRIEF

After careful appraisal of a large number of manufacturers, in 2003 the first distributors were appointed to sell Cgate flexible media for large format printers. Now, three years later, Cgate distributors span 5 continents and over 20 countries. The range of products in the Cgate portfolio has grown from a limited range of frontlit and backlit media to a wide range of materials including One Way Vision, Mesh, Tarpaulin and Blockout.

With the increased range of large format flatbed printers, in 2004 Cgate perceived the need to add a range of rigid materials to the product portfolio. Starting with Cbond, the most popular product for the sign industry and moving on to other products such as Free Form PVC, Acrylic, Fluted Polypropylene as well as Magnetic sheeting, Cgate is now proud to offer a complete range of materials for either direct digital printing or more conventional screen printing. Once again, Cgate distributors have provided a valuable insight into the needs of the market and Cbond is now being used for more diverse applications such as wall cladding and construction.

[www.cgategroup.com](http://www.cgategroup.com)

## Contact us:

### CGATE GROUP

#### Cgate Europe office (London)

2nd Floor  
145-157 St. John Street  
London EC1V 4PY  
Tel: +44 (0)208 908 9229  
Fax: +44 (0)870 1331153  
Mobile: +44 (0)7753 864422  
email: [andi@cgategroup.com](mailto:andi@cgategroup.com)

#### Cgate Europe office (Brussels)

Rue Heideken 15  
1083 Ganshoren  
Brussels 1083  
Belgium  
Tel: +32 2 4286355  
Fax: +32 2 4286355  
Mobile: +32 486987676  
email: [alex@cgategroup.com](mailto:alex@cgategroup.com)

#### Cgate Europe office (Germany)

Weihergrundstraße 17b  
61389 Schmittchen  
Tel: +49 6084 951131  
Fax: +49 6084 951132  
Mobile: +49 172 2806313  
email: [axel.graefnitz@cgategroup.com](mailto:axel.graefnitz@cgategroup.com)

#### Cgate US Office

2915 Pass a Grille Way  
St. Pete Beach, FL 33706  
Cell: 617 429 6056  
Office: 727 367 9793  
email: [CGATEUSA@aol.com](mailto:CGATEUSA@aol.com)

#### CGATE Shanghai

7F B1, Junyao International Plaza  
No.789 zhaojiabang Road  
Shanghai  
CHINA, PRC.  
Tel: 86-21-64229726 / 27 / 28  
Fax: 86-21-64229725  
email: [info@cgategroup.com](mailto:info@cgategroup.com)